

M.E. RINKER, Sr. HALL

SCHOOL OF BUILDING CONSTRUCTION

UNIVERSITY OF FLORIDA-GAINESVILLE
PROJECT NO. BR-191

ARCHITECTS
**CROXTON COLLABORATIVE/
GOULD EVANS ASSOCIATES**

CROXTON COLLABORATIVE ARCHITECTS
475 FIFTH AVENUE
NEW YORK, NY 10017
TEL 212.683.1998
FAX 212.683.2799

GOULD EVANS ASSOCIATES
5405 WEST CYPRESS STREET
TAMPA, FL 33607
TEL 813.288.0729
FAX 813.288.0231

MECHANICAL ENGINEERS
LEHR ASSOCIATES

130 WEST 30TH STREET
NEW YORK, NY 10001-4092
TEL 212.947.8050
FAX 212.967.2059

STRUCTURAL ENGINEERS
WALTER P. MOORE

201 EAST KENNEDY BOULEVARD
TAMPA, FL 33602
TEL 813.221.2424
FAX 813.221.2289

CIVIL ENGINEERS
BROWN & COLLEH, INC.

3530 NW 43 STREET
GAINESVILLE, FL 32605
TEL 352.375.8999
FAX 352.375.0833

LANDSCAPE ENGINEERS
McCLAIN DESIGN GROUP, INC.

1843 NW 39 DRIVE
GAINESVILLE, FL 32605
TEL 352.372.2808
FAX 352.372.6622

CONSULTANT
SEEGY-BISCH

AUSSERE SULZBACHER STR. 118
NURNBERG, GERMANY
TEL 0911/59 90 99
FAX 0911/59 98 05

THIS DRAWING, AS AN INSTRUMENT OF SERVICE, IS AND SHALL REMAIN, PROPERTY OF CROXTON COLLABORATIVE ARCHITECTS. THIS DRAWING SHALL NOT BE REPRODUCED, PUBLISHED, USED ON OTHER PROJECTS, USED FOR ADDITIONS, OR USED IN COMPLETION OF THIS PROJECT BY OTHERS WITHOUT THE WRITTEN AGREEMENT OF CROXTON COLLABORATIVE ARCHITECTS/GOULD EVANS ASSOCIATES.

FIRST LETTER: DESIGNATES WALL (W) OR PARTITION (P)
SECOND LETTER: DESIGNATES ASSEMBLY RATING, 0 FOR NON-RATED 1 FOR 1-HOUR RATED ASSEMBLY, ETC.
LAST TWO LETTERS: DESIGNATE THE WALL/PARTITION NUMBER IN SEQUENCE

P001

100% CONSTRUCTION DOCUMENTS

DATE: 11/21/01
SCALE: 3/4"=1'-0"
DRAWN BY/CHIEFED BY: MM/JRae
DRAWING NUMBER: **A701**

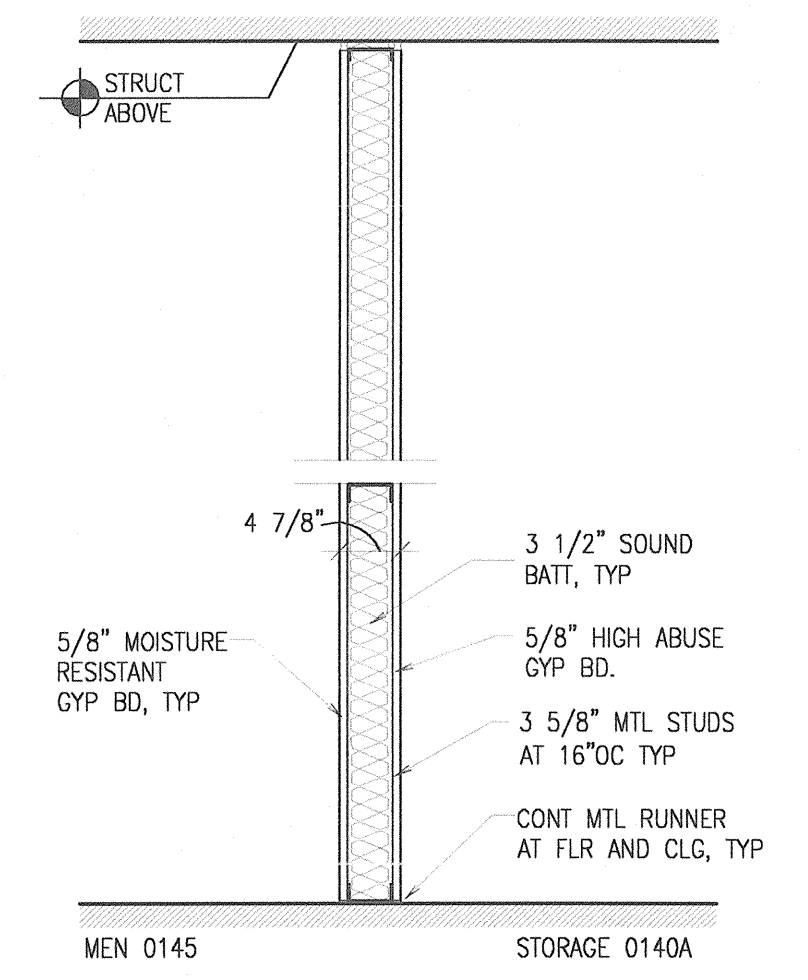

W011
23 WALL TYPE
3/4" = 1'-0"

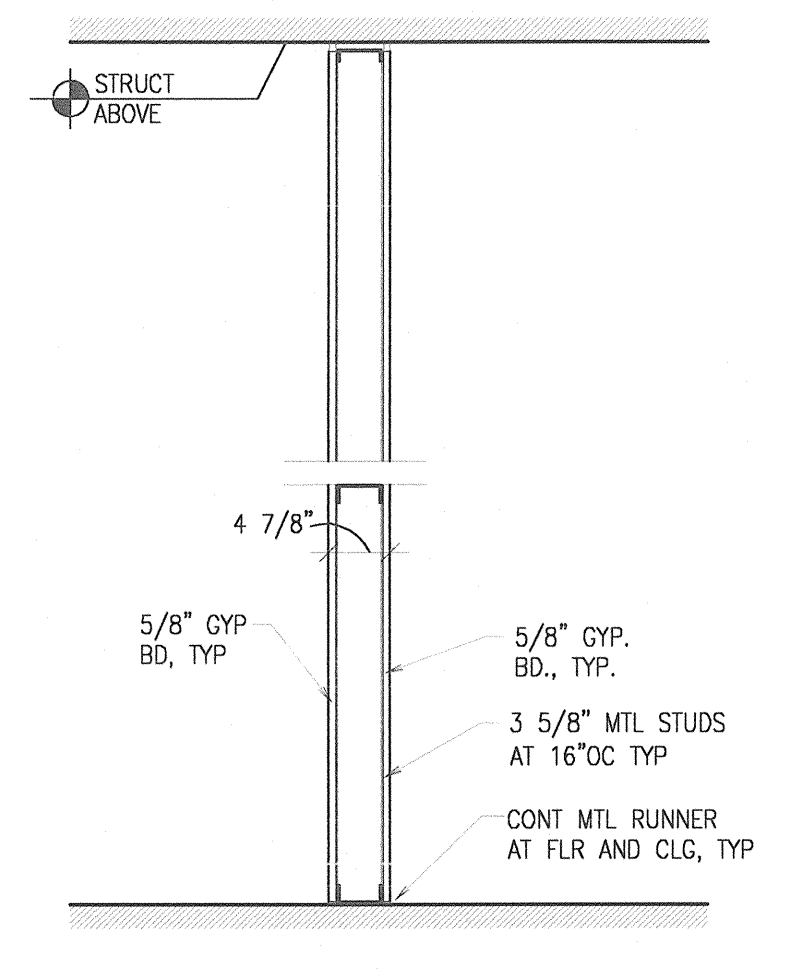

W012
24 WALL TYPE
3/4" = 1'-0"

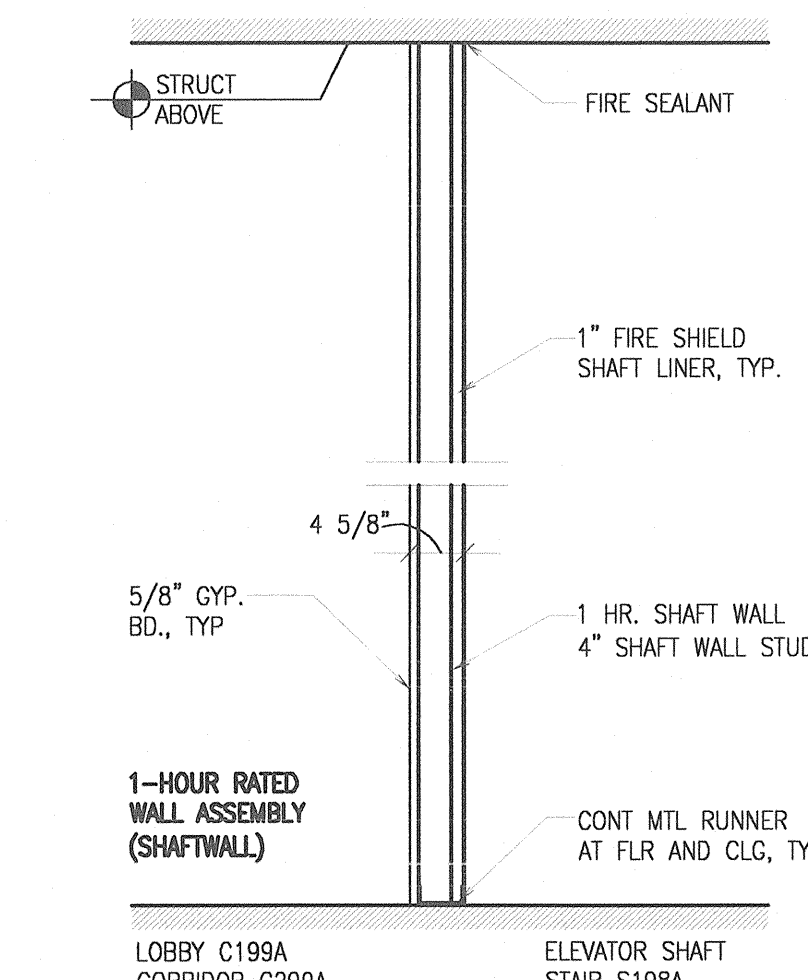

W101
25 RATED WALL TYPE
3/4" = 1'-0"

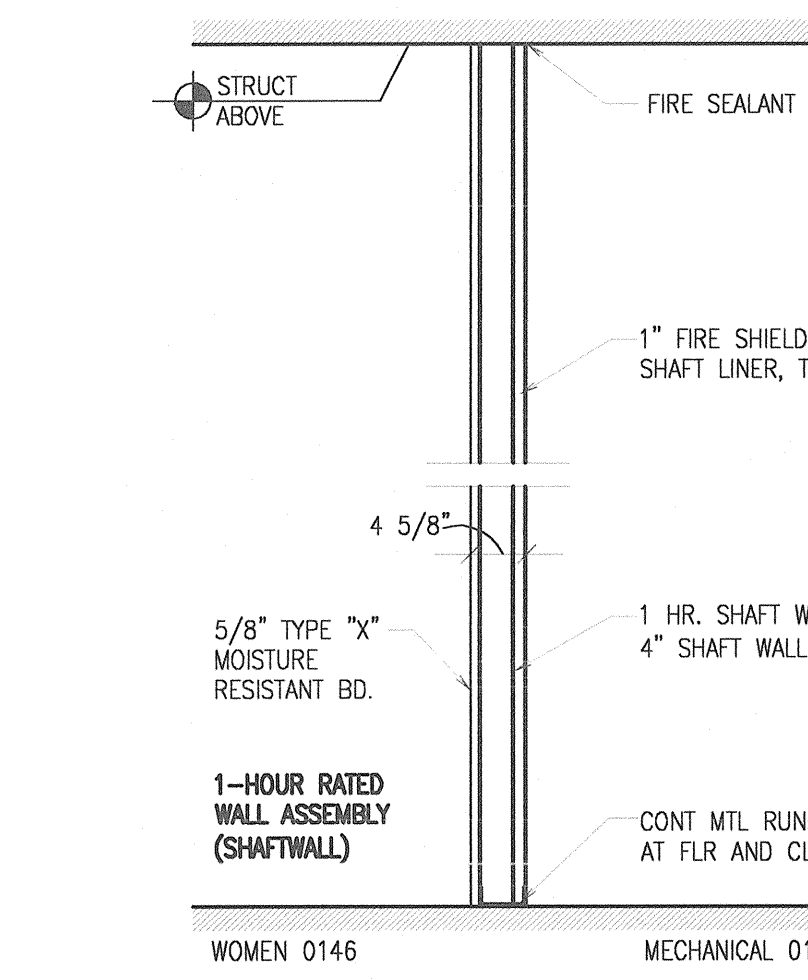

W102
26 RATED WALL TYPE
3/4" = 1'-0"

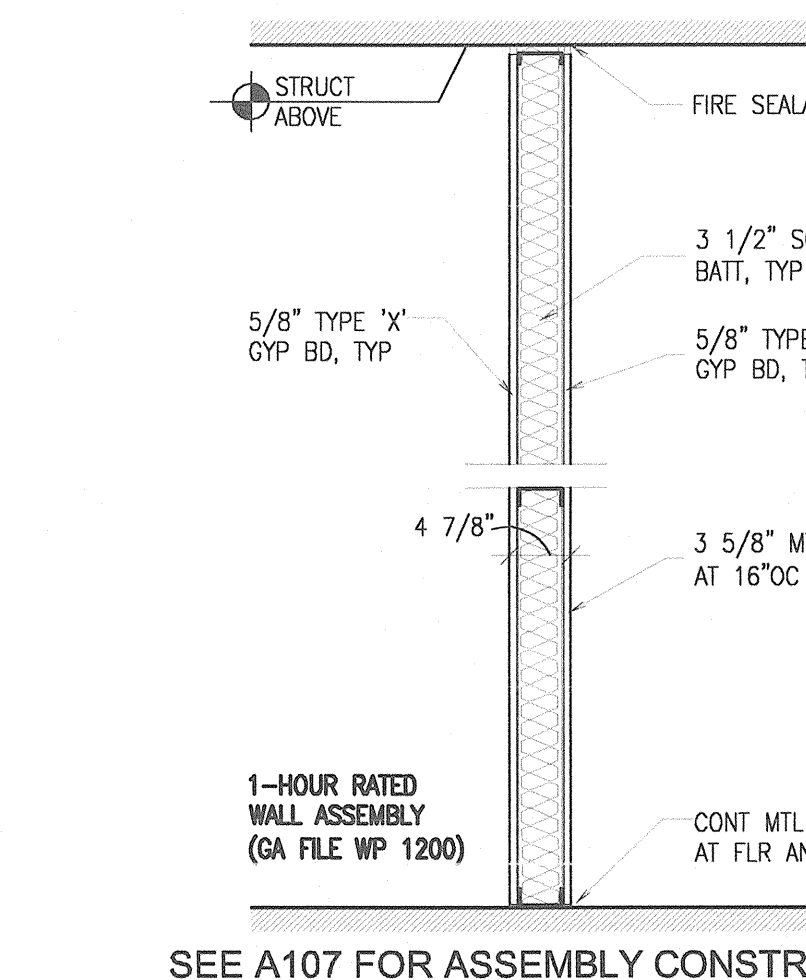

W103
27 RATED WALL TYPE
3/4" = 1'-0"

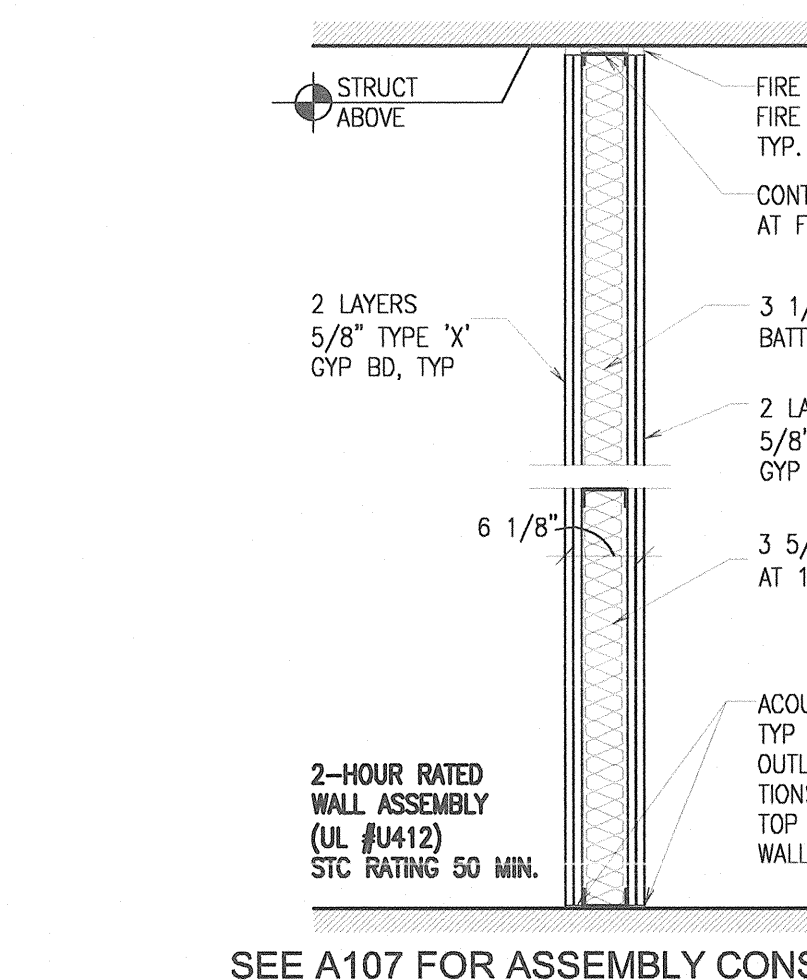

W201
28 RATED WALL TYPE
3/4" = 1'-0"

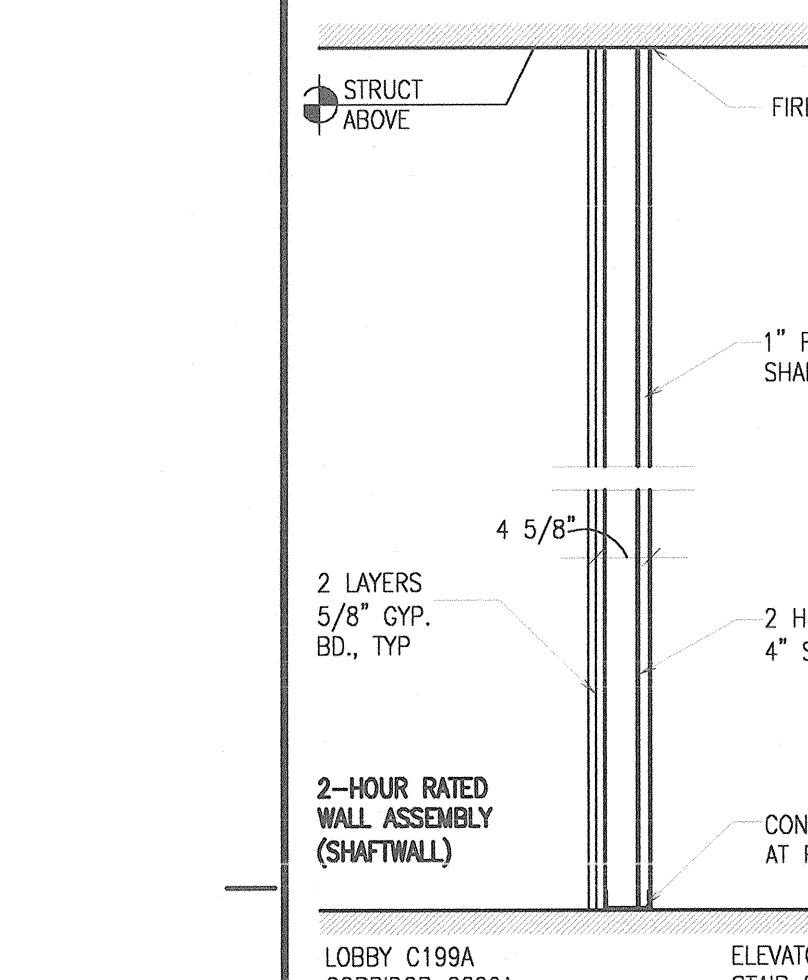

W202
25 RATED WALL TYPE
3/4" = 1'-0"

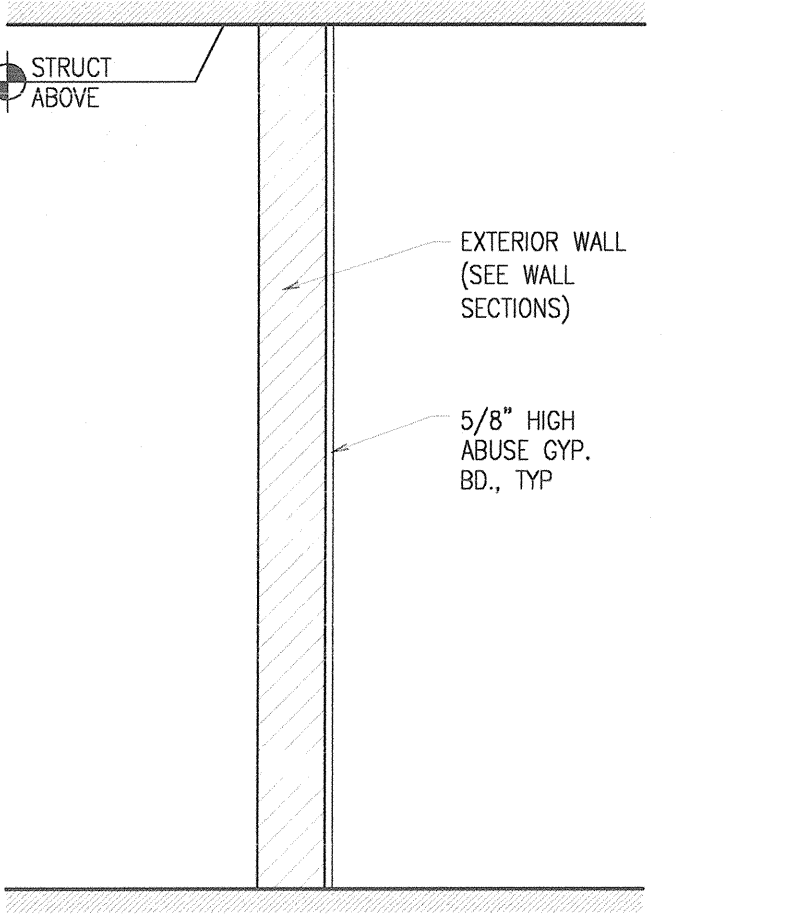

W004
16 WALL TYPE
3/4" = 1'-0"

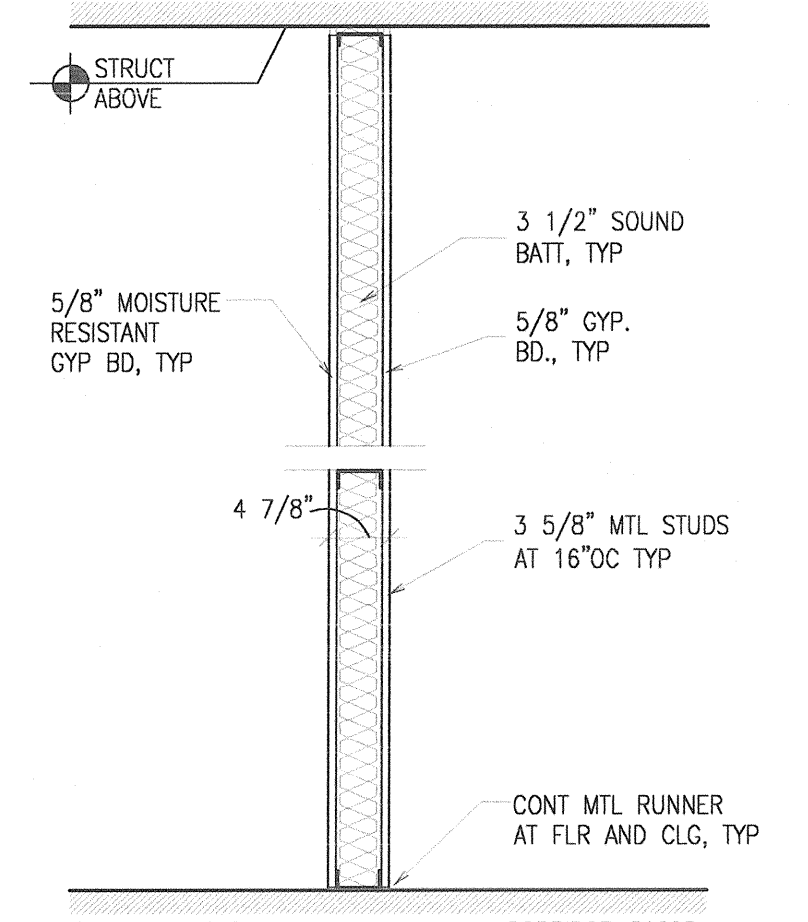

W005
17 WALL TYPE
3/4" = 1'-0"

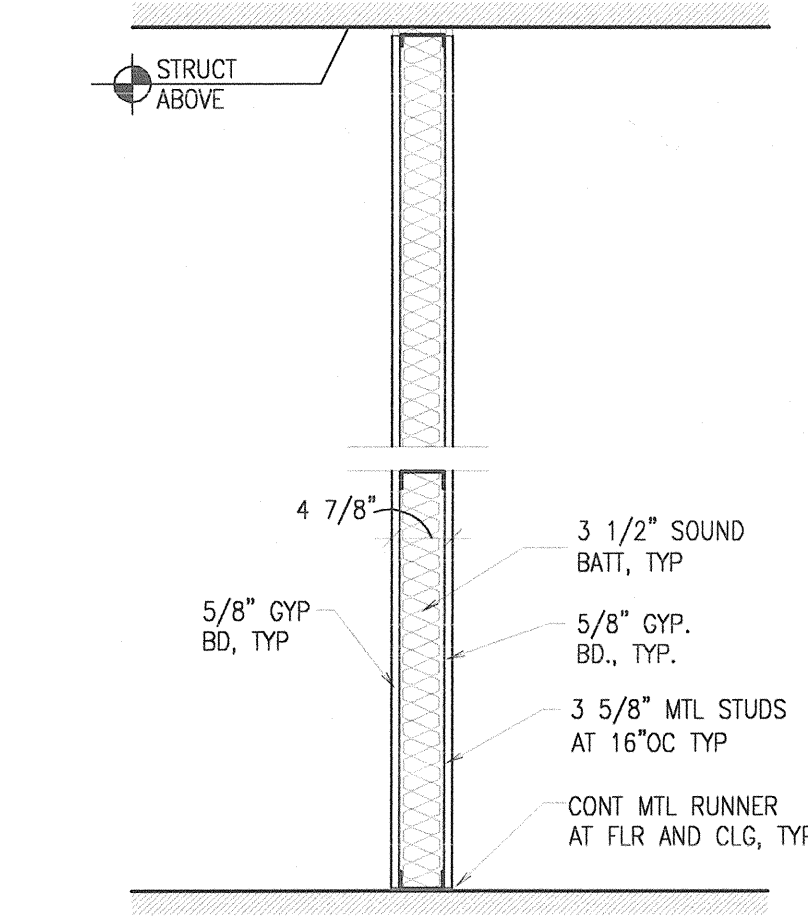

W006
18 WALL TYPE
3/4" = 1'-0"

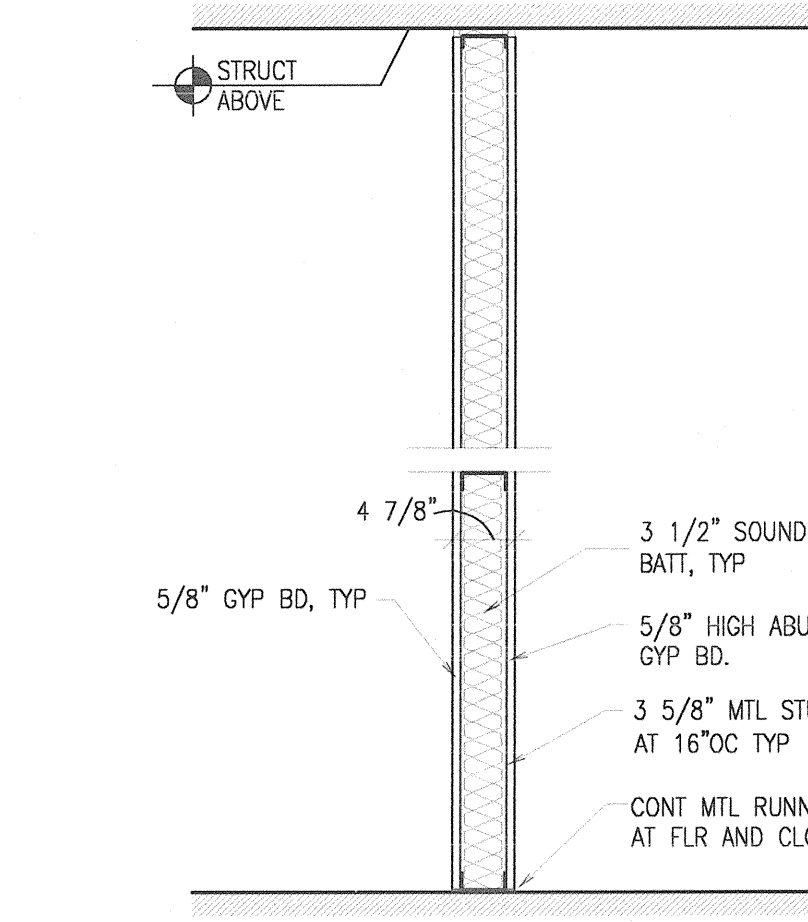

W007
19 WALL TYPE
3/4" = 1'-0"

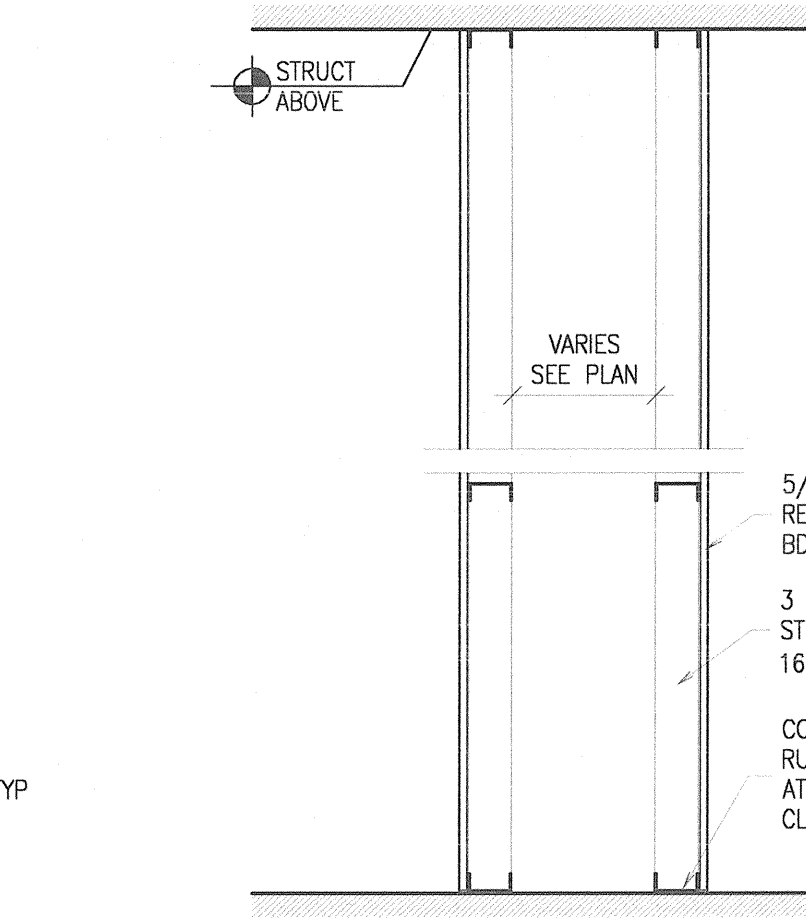

W008
20 WALL TYPE
3/4" = 1'-0"

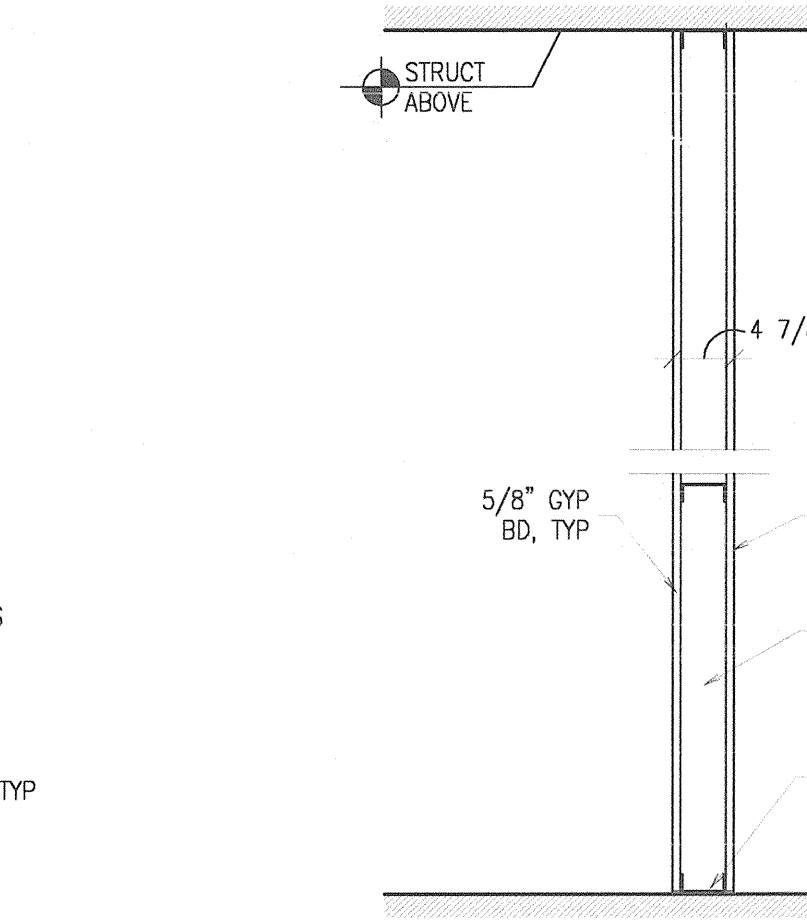

W009
21 WALL TYPE
3/4" = 1'-0"

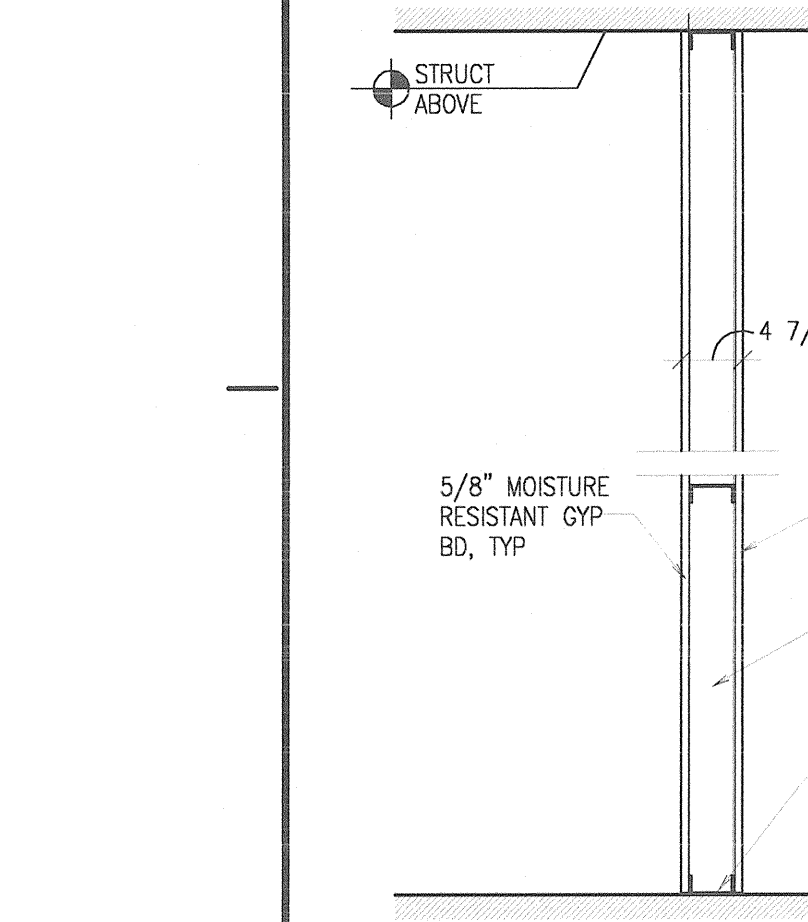

W010
22 WALL TYPE
3/4" = 1'-0"

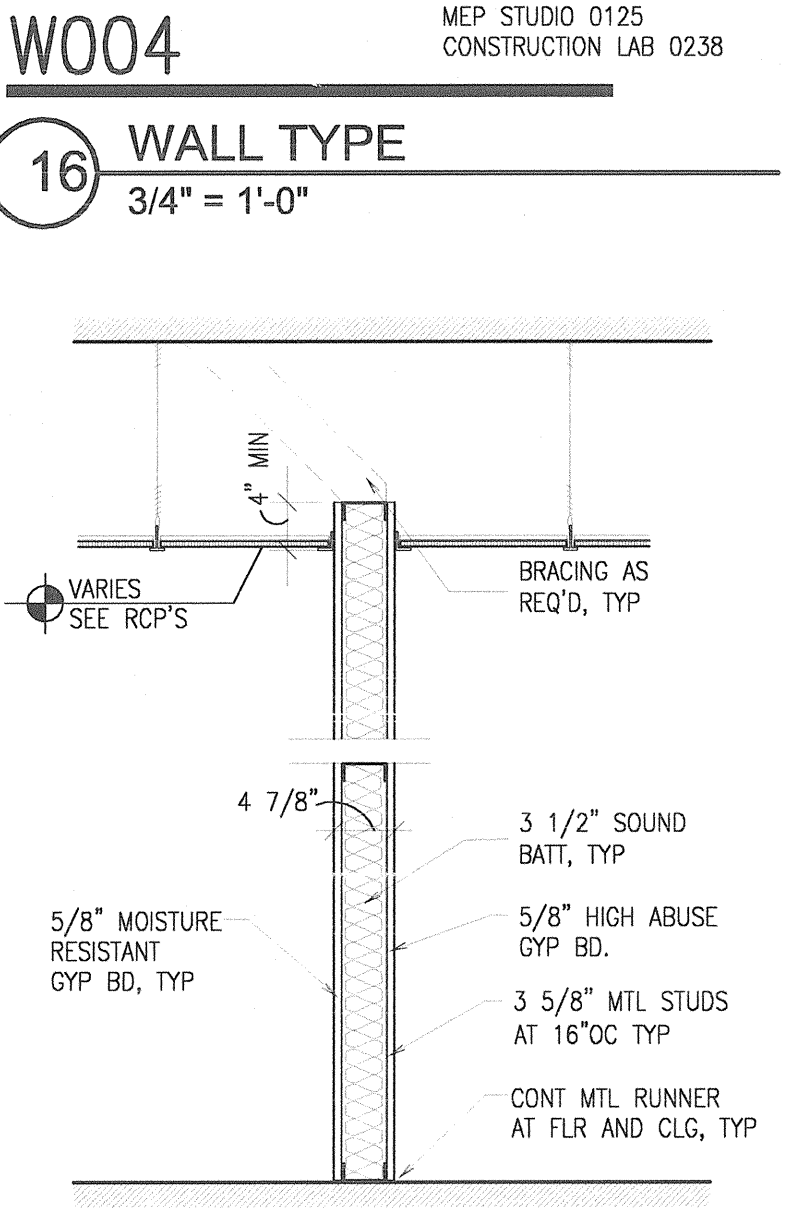

P007
8 PARTITION TYPE
3/4" = 1'-0"

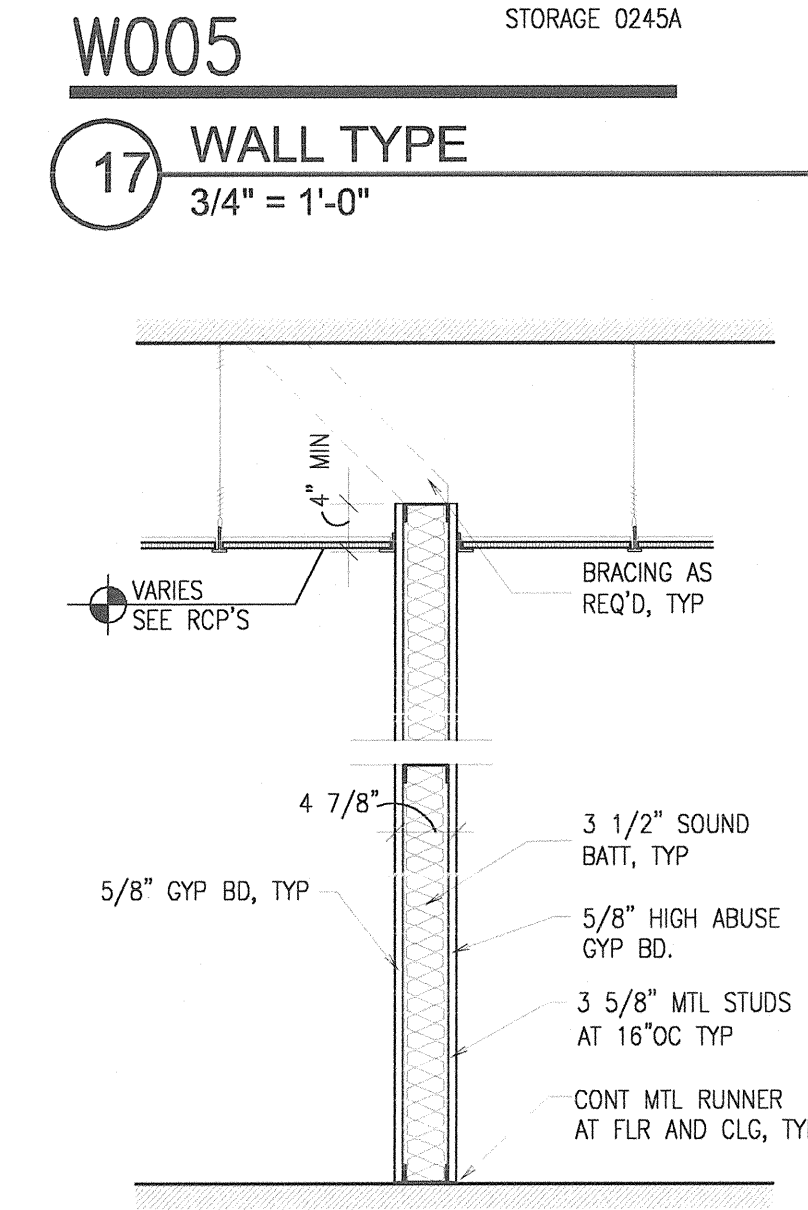

P008
9 PARTITION TYPE
3/4" = 1'-0"

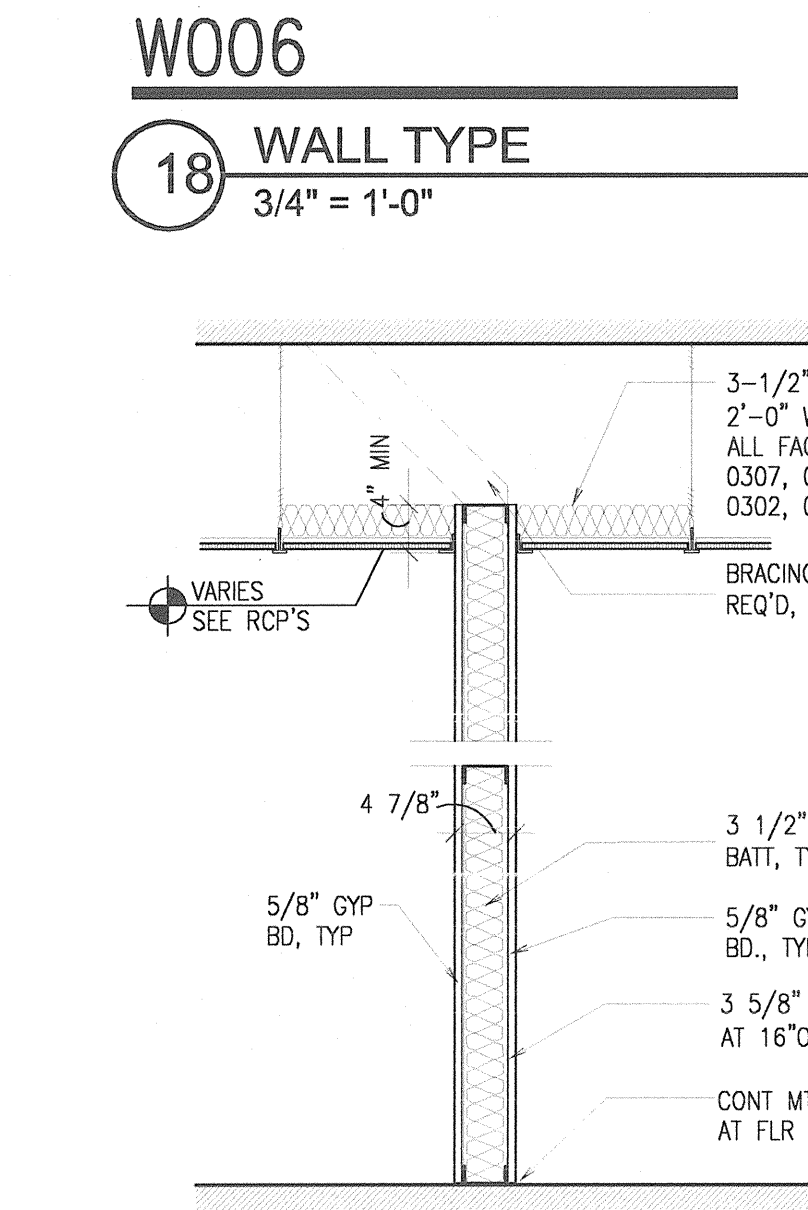

P010
11 PARTITION TYPE
3/4" = 1'-0"

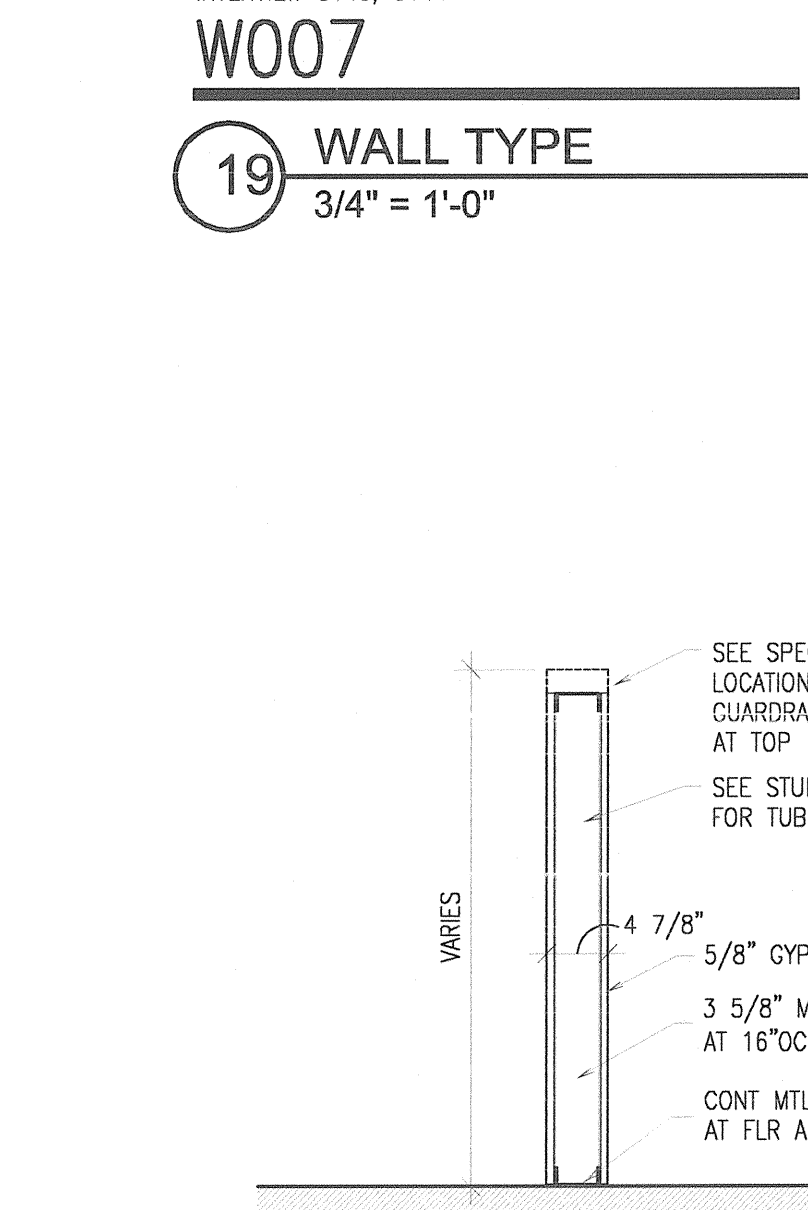

P011
12 PARTITION TYPE
3/4" = 1'-0"

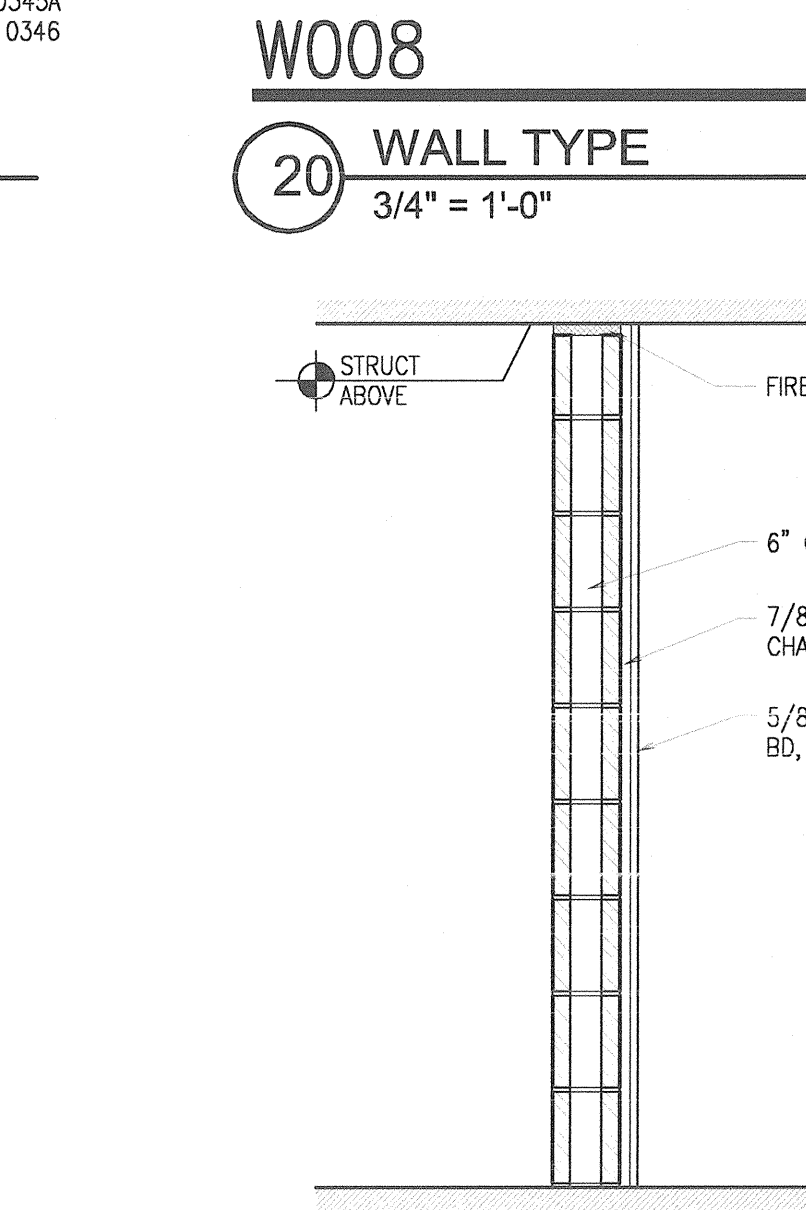

W001
13 WALL TYPE
3/4" = 1'-0"

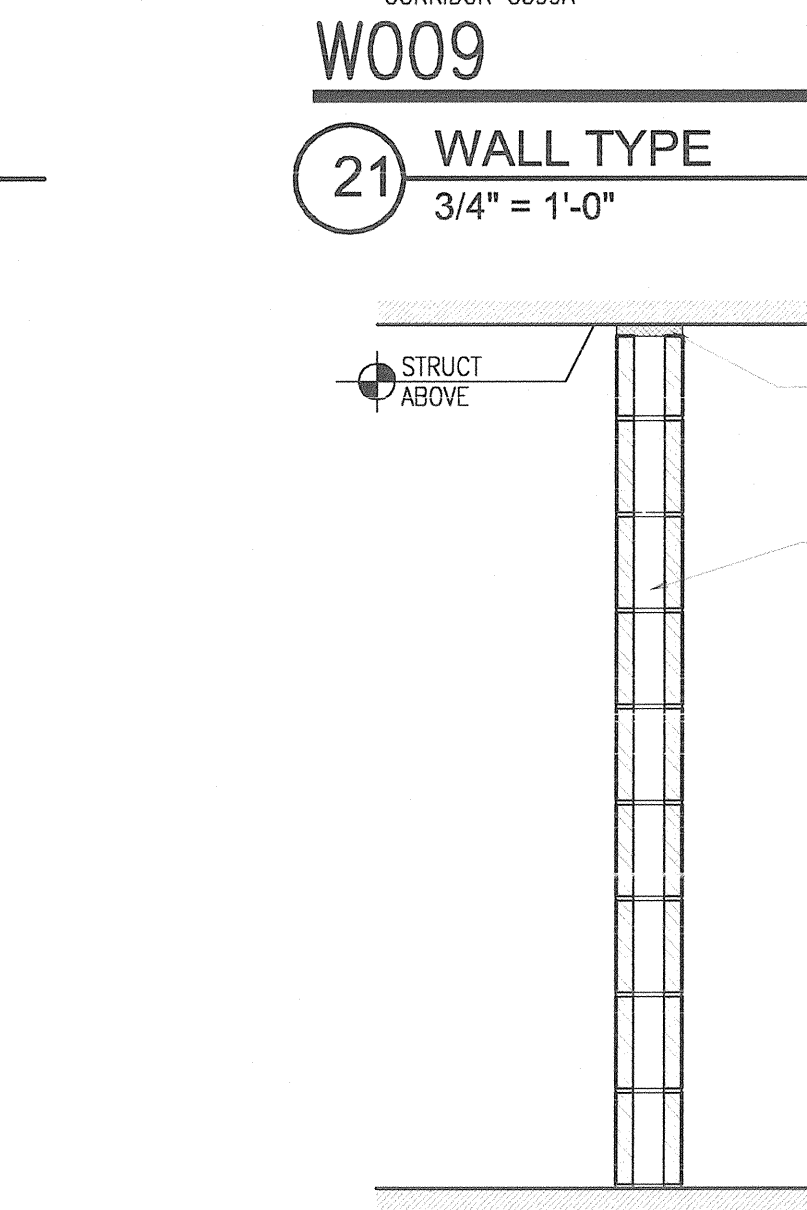

W002
14 WALL TYPE
3/4" = 1'-0"

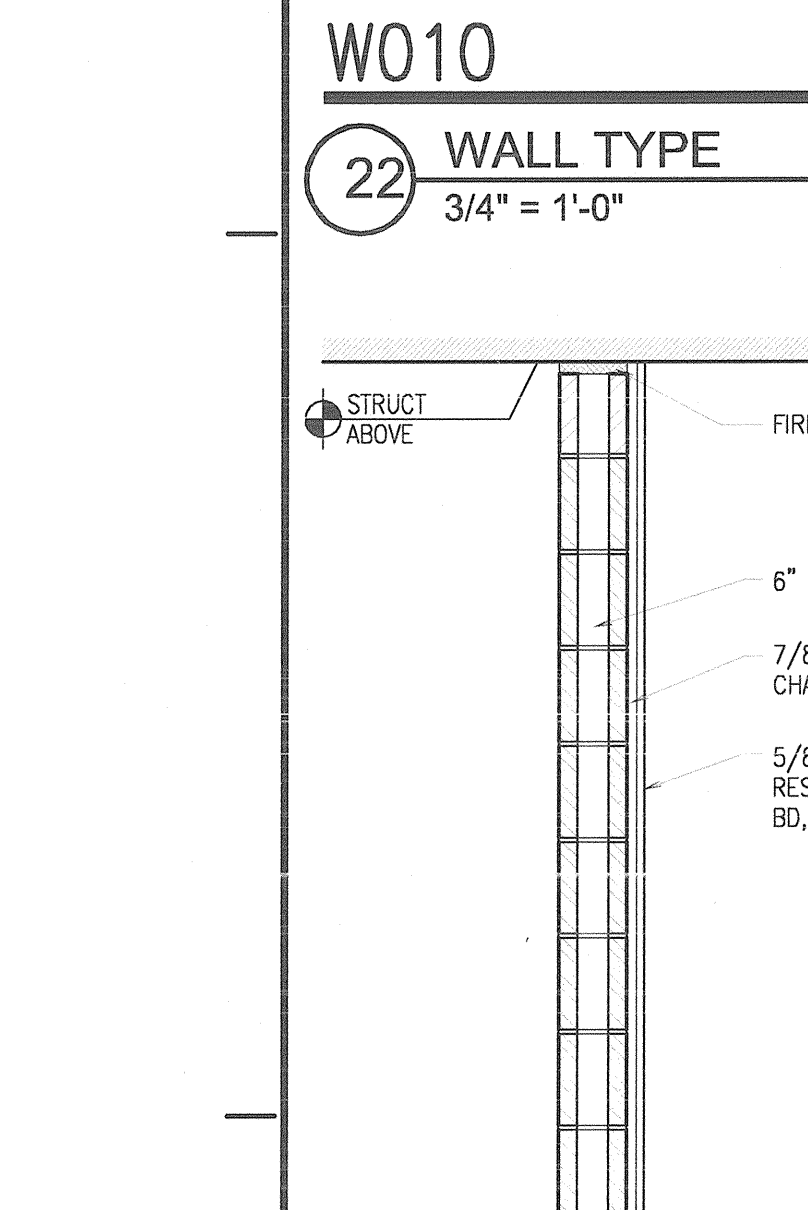

W003
15 WALL TYPE
3/4" = 1'-0"

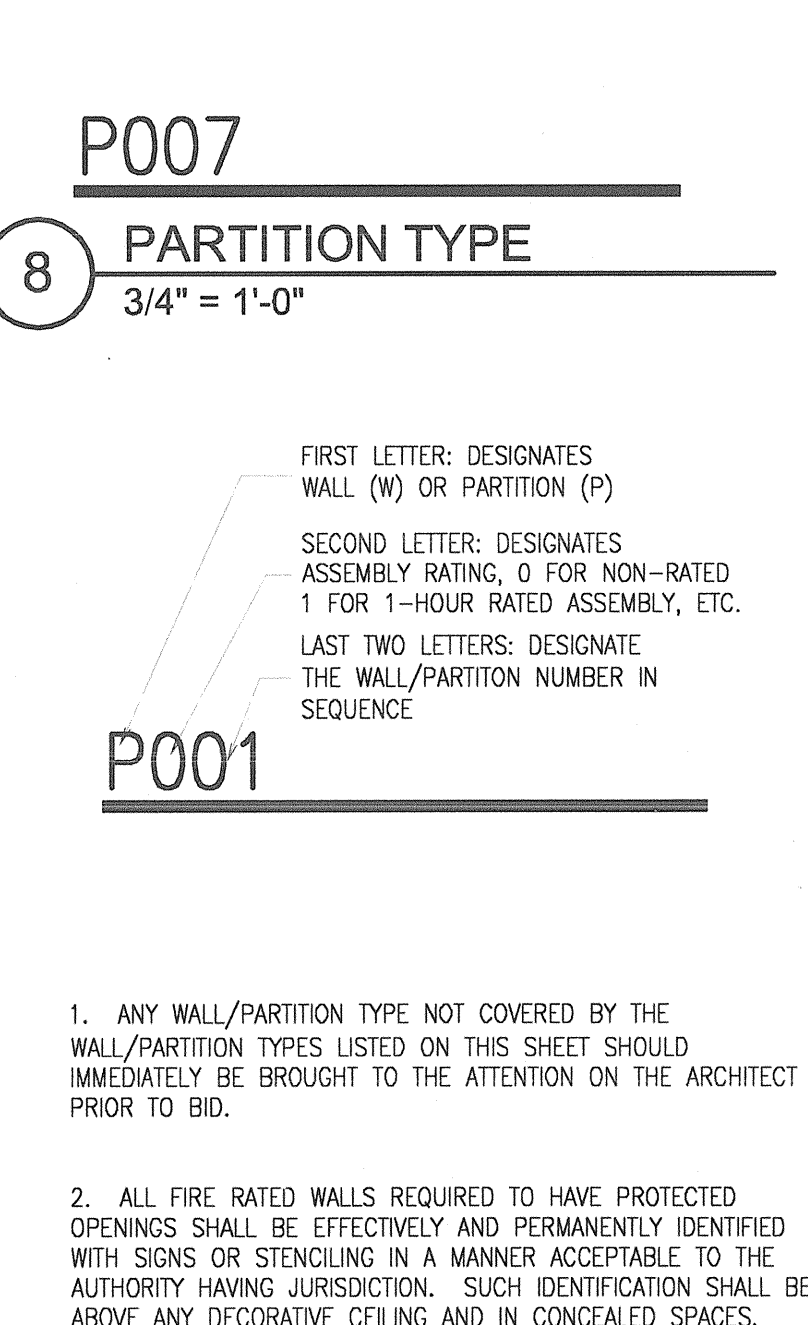

P001
1 GENERAL NOTES
3/4" = 1'-0"

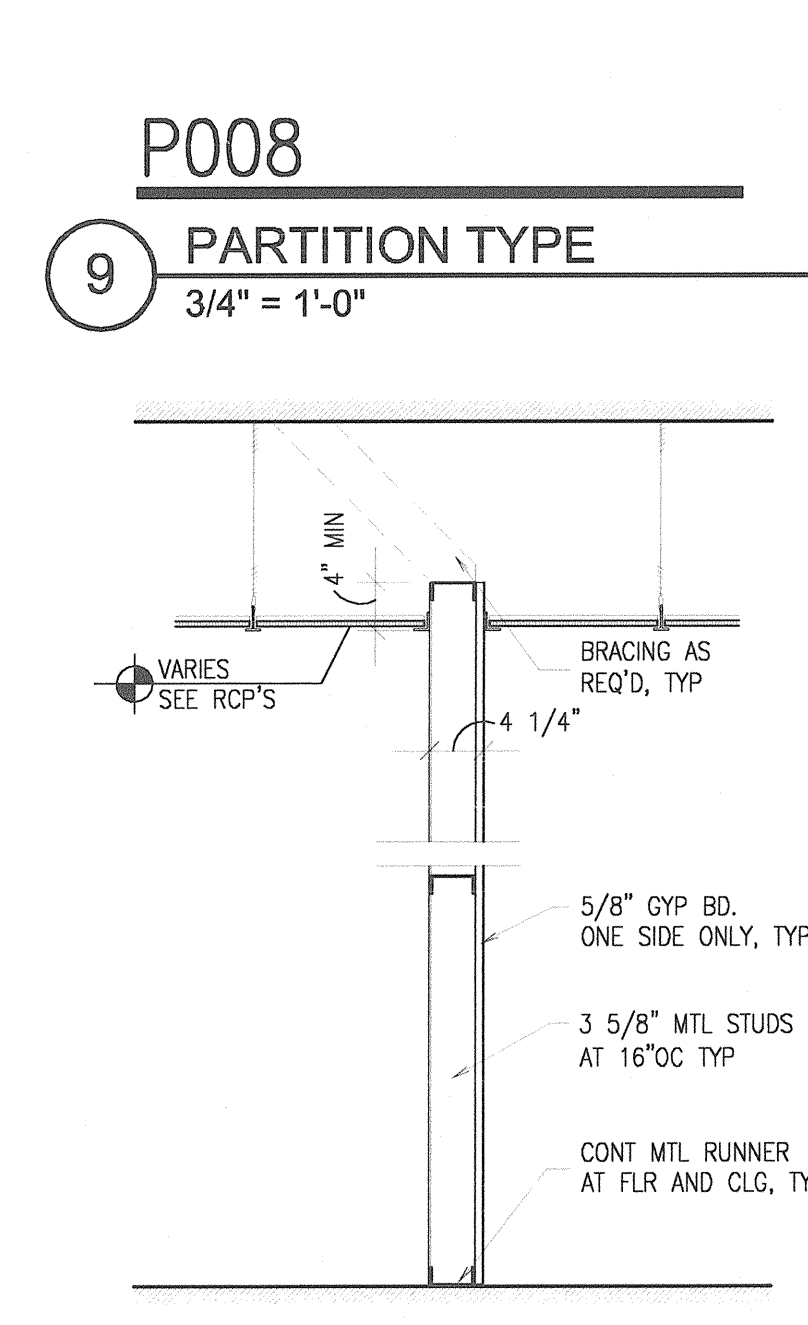

P002
2 PARTITION TYPE
3/4" = 1'-0"

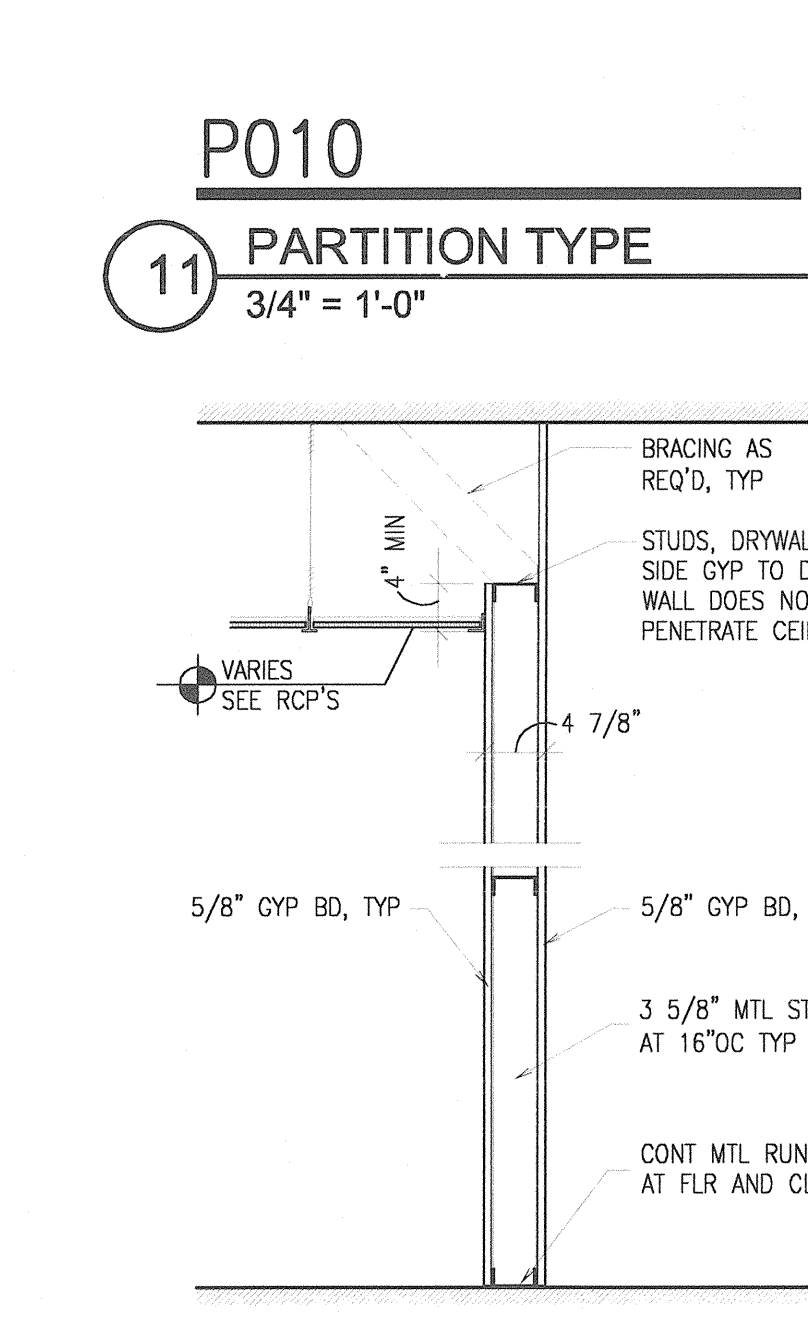

P003
3 PARTITION TYPE
3/4" = 1'-0"

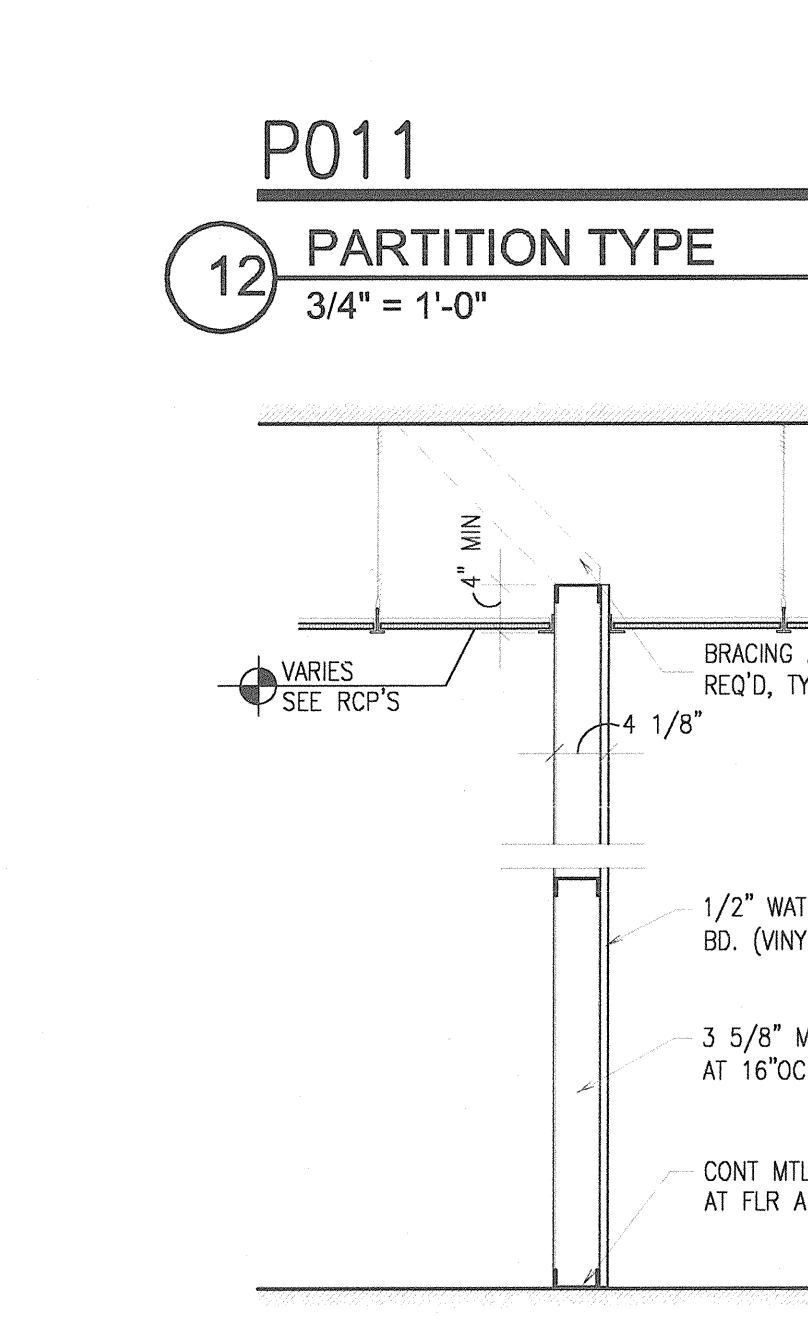

P004
4 PARTITION TYPE
3/4" = 1'-0"

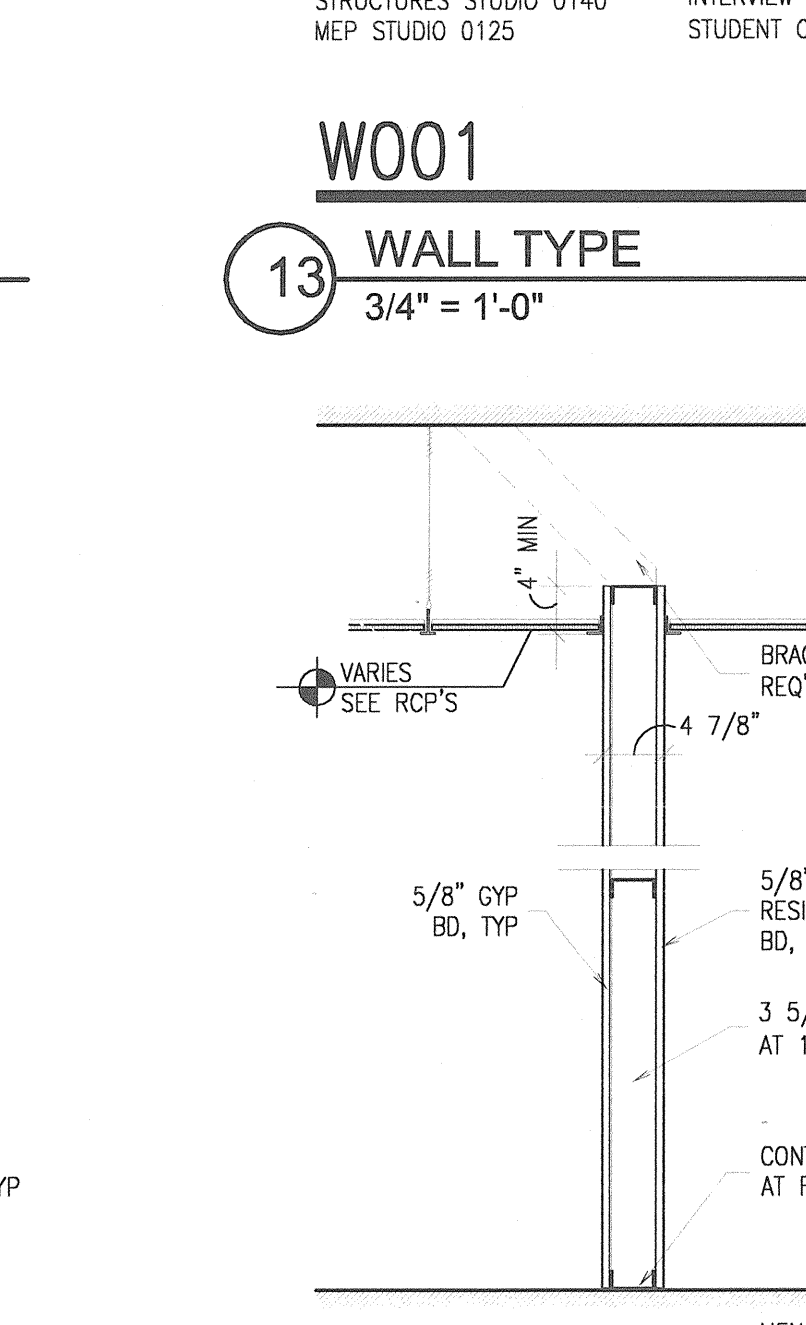

P005
5 PARTITION TYPE
3/4" = 1'-0"

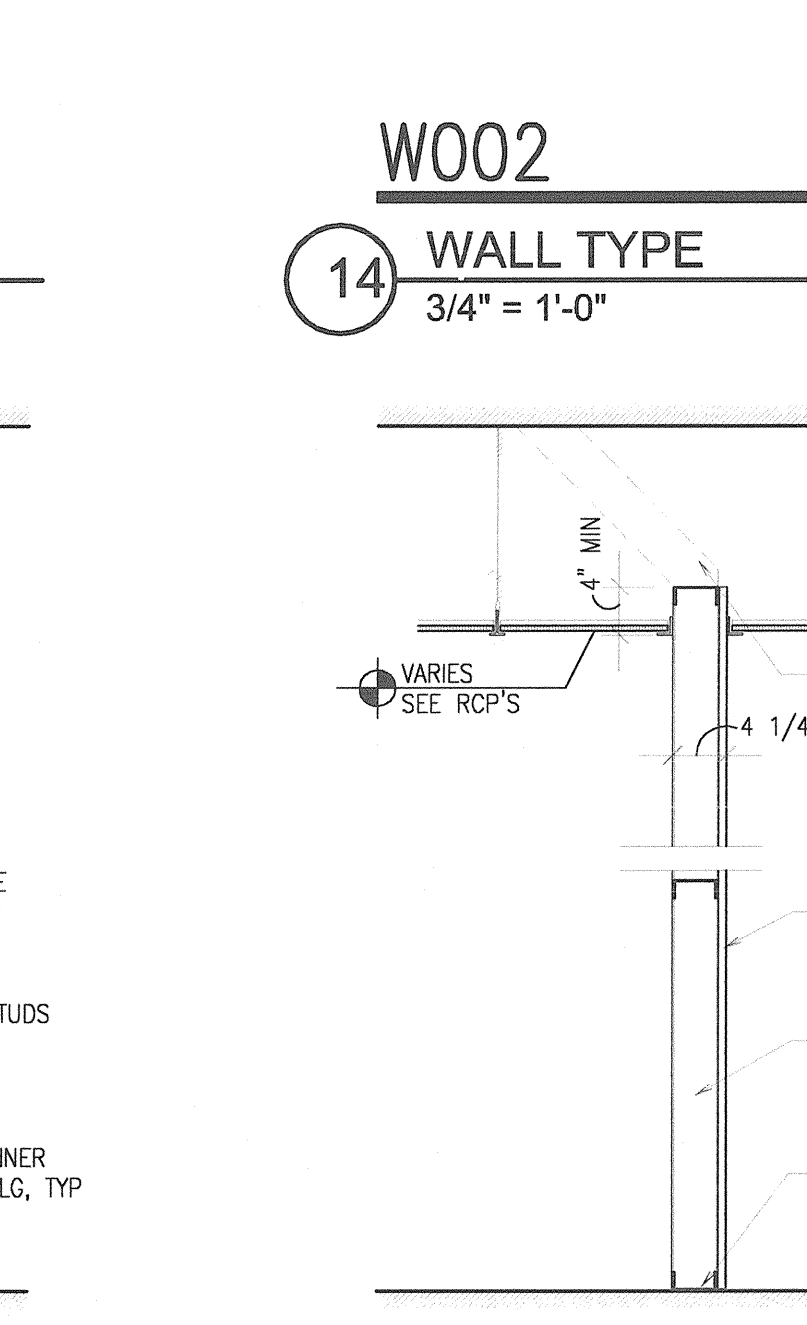

P006
7 PARTITION TYPE
3/4" = 1'-0"

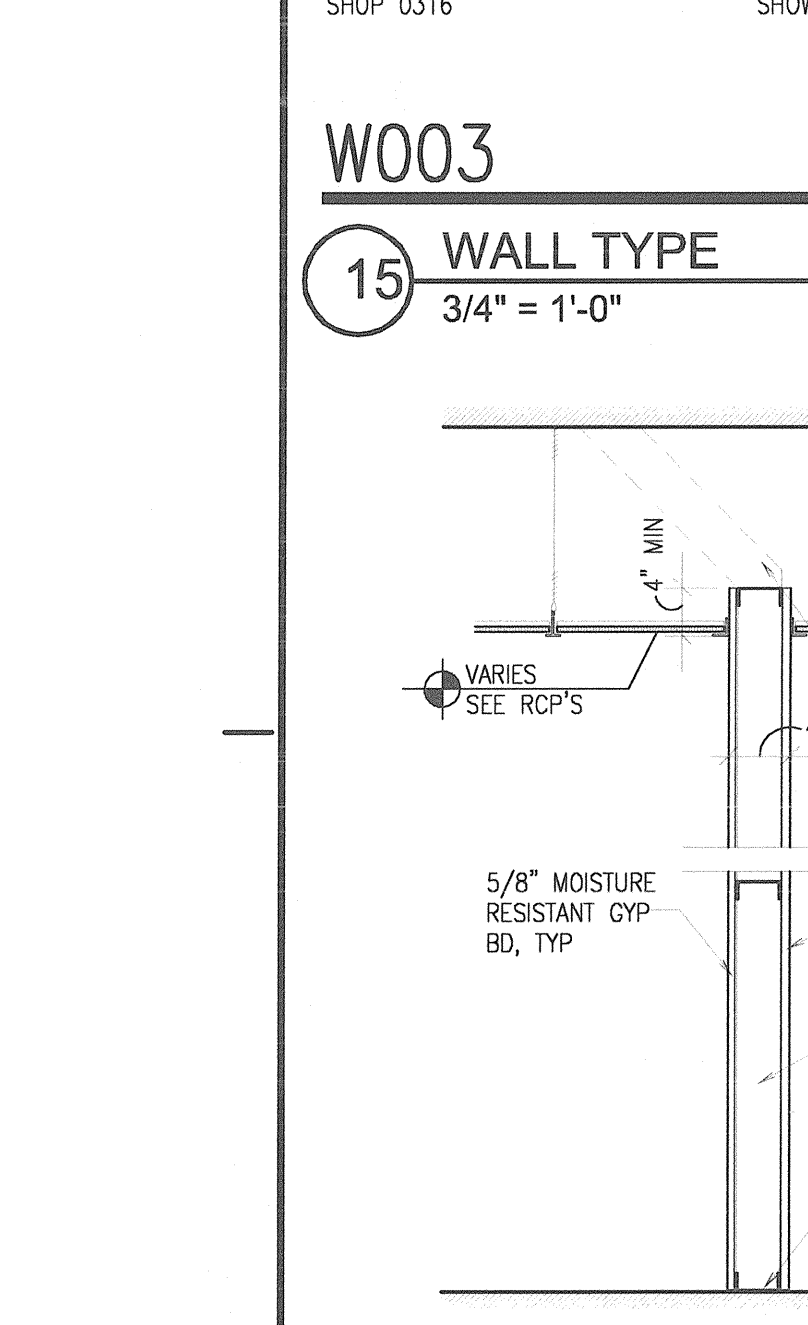

P007
15 WALL TYPE
3/4" = 1'-0"

1. ANY WALL/PARTITION TYPE NOT COVERED BY THE WALL/PARTITION TYPES LISTED ON THIS SHEET SHOULD IMMEDIATELY BE BROUGHT TO THE ATTENTION OF THE ARCHITECT PRIOR TO BID.

2. ALL FIRE RATED WALLS REQUIRED TO HAVE PROTECTED OPENINGS SHALL BE EFFECTIVELY AND PERMANENTLY IDENTIFIED WITH SIGNS OR STENCILING IN A MANNER ACCEPTABLE TO THE AUTHORITY HAVING JURISDICTION. SUCH IDENTIFICATION SHALL BE ABOVE ANY DECORATIVE CEILING AND IN CONCEALED SPACES. SUGGESTED WORDING: "FIRE AND SMOKE BARRIER PROTECT ALL OPENINGS".

4. NOT ALL WALL/PARTITION TYPES USED. P009 NOT USED.